

# 2 WORKER CARRY AIR with CO MONITOR (9872) 2 WORKER WALL AIR with CO MONITOR (9872-40)

## 2 Worker Carry Air w/CO (9872)

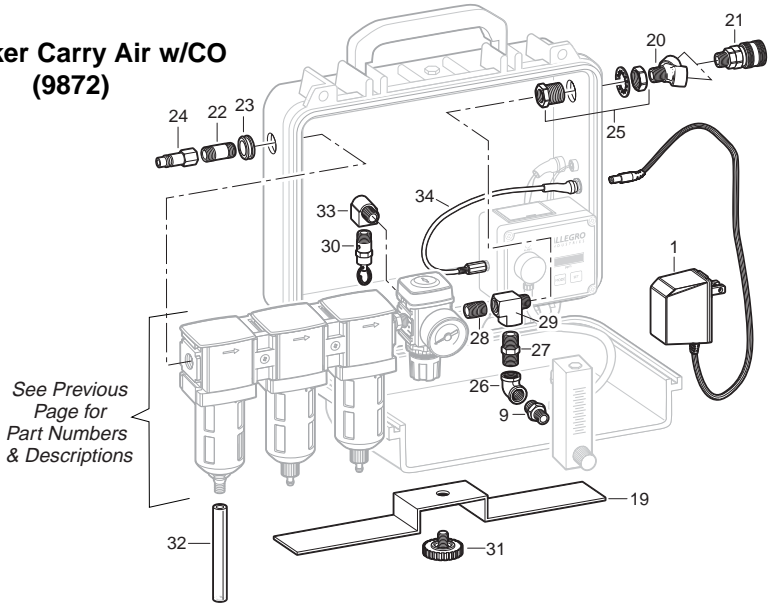
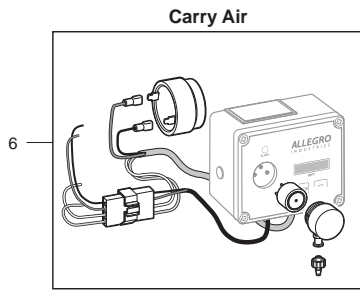

See Previous Page for Part Numbers & Descriptions

## 2 Worker Wall Air w/CO (9872-40)

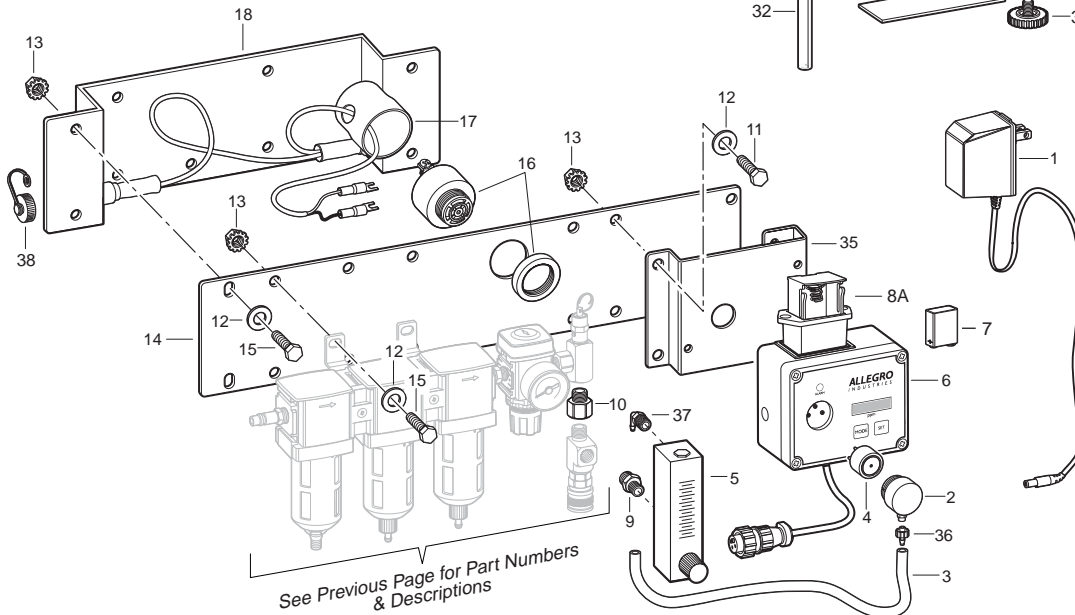

See Previous Page for Part Numbers & Descriptions

Before 09-2004

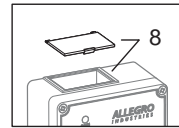

After 09-2004

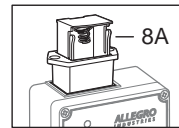

Key	Part #	Description	Key	Part #	Description	Key	Part #	Description
	<b>9872</b>	<b>2 Worker Carry Air w/CO</b>						
	<b>9872-40</b>	<b>2 Worker Wall Air w/CO</b>						
1	9872-95	AC to DC Power Supply	10	9875-25	Adapter	28	9872-29	Close Nipple
2	9872-92	CO Sensor Cover	11	9800-74	Tap Bolt	29	9872-27	Street Elbow
3	9872-14	Poly Flow Tubing	12	9800-62	Flat Washer	30	9875-09	Relief Valve
4	9872-69	CO Sensor (Purchased after 7/98)	13	9500-67	K-Nut	31	9872-30A	Support Stand Retainer Screw
5	9872-25	Flow Meter	14	9865-06C	Filter Panel Plate	32	9872-13	Poly Flow Tubing
6	9872-02B	CO Monitor for Wall Air (Includes 1, 2, 4, 6-8)	15	9500-79	Tap Bolt	33	9872-18	Adaptor
	9872-02BC	CO Monitor for Carry Air (Includes 1, 2, 4, 6-8)	16	9871-01D	Piezo Alarm	34	9872-88	DC Cable Extension
7	9871-01F	Battery	17	9871-01N	Alarm Cover	35	9865-17	Monitor Bracket (Wall Air)
8	9872-91	Battery Compartment Cover (not sold separately)	18	9865-05C	Panel Mount Bracket Assembly	36	9872-14B	Male Luer
	9872-91A	Battery Compartment (Purchased before 09-2004)	19	9872-30	Support Stand	37	9872-17	Elbow
8A	9872-91B	Battery Compartment (Purchased after 09-2004)	20	9872-10	Y - Connector	38	9872-85	Receptacle Cap
9	9872-28	Adapter	21		Coupler (See Page 49)	<b>Parts and Accessories</b>		
			22	9872-20	Nipple	9872-60	Co Monitor Calibration Kit (2 Gases; 1 Regulator; 1 Tubing)	
			23	9872-12	Grommet	9872-61	Calibration Span Gas, 17 Liter Bottle	
			24	8400-04	Plug	9872-62	Calibration Zero Gas 17 Liter Bottle	
			25	9872-11	Bulkhead			
			26	9872-26	Union Elbow, Female			
			27	9000-25	Hex Nipple			